

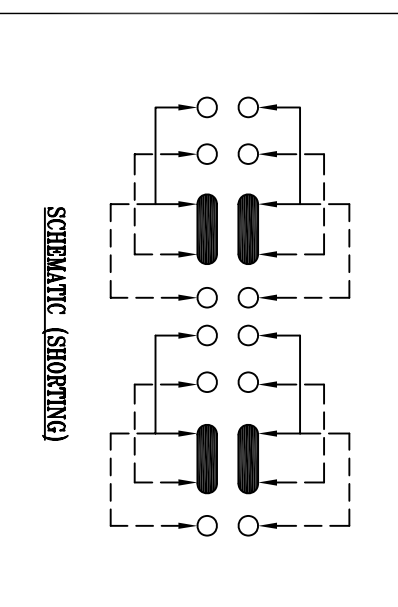

CAD FILE:

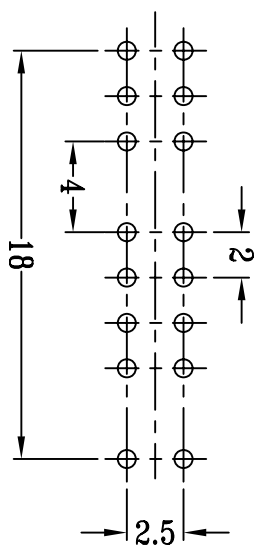
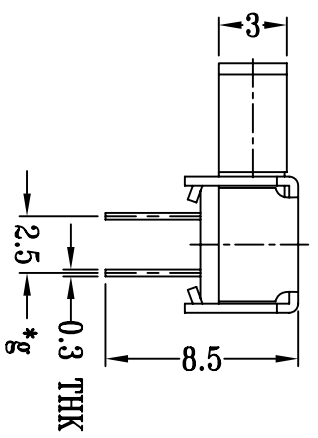
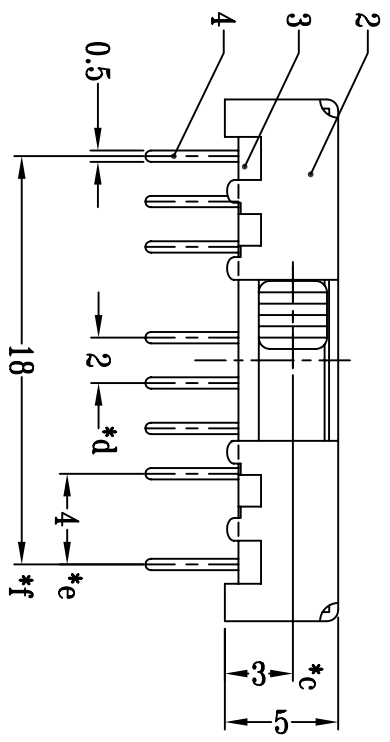
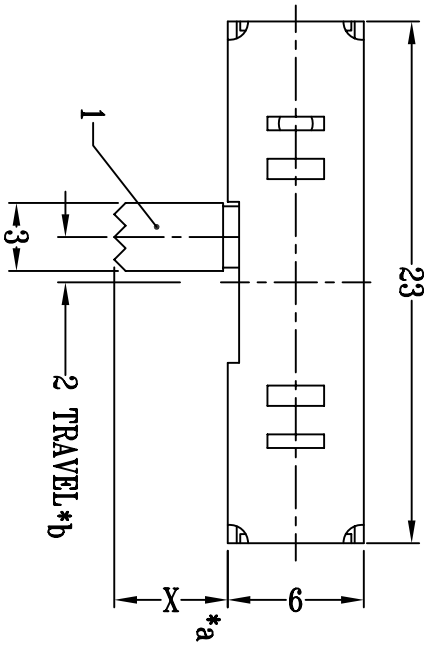

注：“*”表示关键尺寸（7个）

8																						
7	STEEL BALL	STEEL	1	NATURAL	TOLERANCE UNLESS SPECIFIED		SHENZHEN XIEJIA ELECTRONICS CO.,LTD.															
6	SPRING	STEEL WIRE	1	TEMPER	WITHIN: 1.5±0.1mm																	
5	CONTACT CLIP	PBS STRIP	4	Ag PLATED	OVER : 1.5±0.2mm		ISSUE	DATE	DESCRIPTIONS OF REVISION	APPD.												
4	TERMINAL	BRASS STRIP	16	Ag PLATED OVER NI PLATED	TITLE : HORIZONTAL SLIDE SWITCH		UNIT : mm															
3	BASE	PHENOLIC RESIN	1	NATURAL	MODEL: SK-43D08		SCALE: 3:1															
2	FRAME	STEEL STRIP	1	Ni PLATED	ALL MATERIALS MUST BE COMPLIANT TO ROHS										DMN. ZHOUYU	2004-9-6						
1	KNOB	POM	1	BLACK											CHK'D FANGYING	2004-9-6						
NO.	PARTS	MATERIALS	QTY	FINISH											APPD. KANGXINAN	2004-9-6						